

Product Description

The RBS611 is a high performance Gallium Arsenide single pole four through broad band RF switch. It is suitable for use in broadband communications and instrumentation applications. A short circuit reflective termination is presented at the isolated outputs of the switch. Control is effected by the application of complimentary 0V and -5V levels to the control lines in accordance with the truth table below.

Applications

- GSM Dual Band Handsets
- Antenna Switch Modules
- Military Radio Systems
- Space Equipments

Features

- Broadband performance
- Low Insertion Loss; 0.7dB typ at 1 GHz
- Ultra low DC power consumption
- Fast switching speed; 2.2nS typical
- Package: 3.0 x 3.0 x 0.75mm³ QFN16 Package

Functional Block Diagram

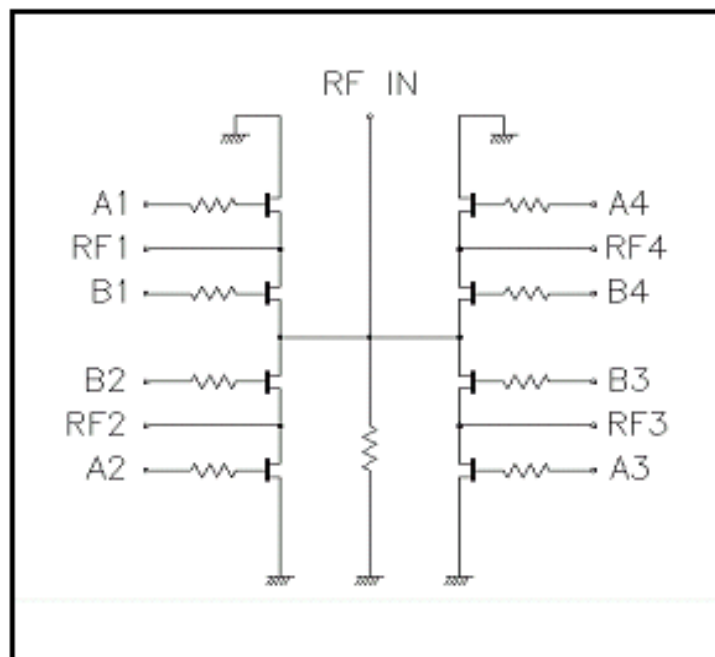

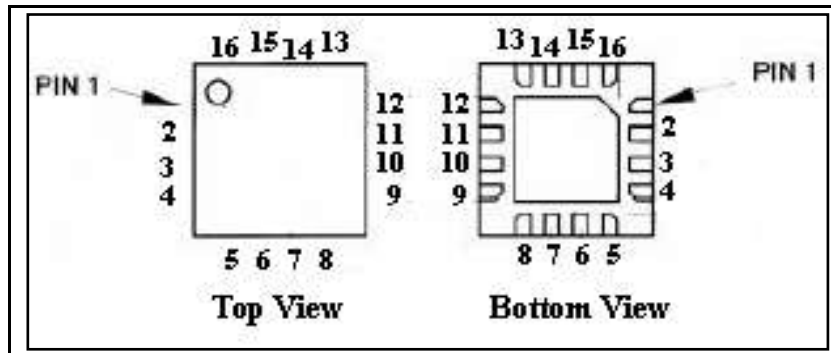
Outline Drawing

Pin Configuration

Pin No.	Name	Description
1	RF4	RF Port
2	Ground	RF Ground
3	RFIN	RF Port
4	Ground	RF Ground
5	RF1	RF port
6	A1	DC Control Voltage (0/-5V) to ON/OFF RF1
7	B1	DC Control Voltage (0/-5V) to ON/OFF RF1
8	B2	DC Control Voltage (0/-5V) to ON/OFF RF2
9	A2	DC Control Voltage (0/-5V) to ON/OFF RF2
10	RF2	RF port
11	Ground	RF Ground
12	RF3	RF port
13	A3	DC Control Voltage (0/-5V) to ON/OFF RF3
14	B3	DC Control Voltage (0/-5V) to ON/OFF RF3
15	B4	DC Control Voltage (0/-5V) to ON/OFF RF4
16	A4	DC Control Voltage (0/-5V) to ON/OFF RF4

Specifications

Absolute Maximum Ratings

Name	Description
Max Control Voltage	-8 V
RF I/P Power	+30 dBm
Operating Temperature Range	-40 to +85° C

Electrical Performance

Typical performance at 25°C

Ambient temperature = 25±3°C, Zo = 50 Ω, Control voltage = 0V/-5V unless otherwise stated

Parameter	Condition	Min.	Typ.	Max.	Units
Insertion Loss ¹	DC – 1 GHz	-	0.7	0.9	dB
	1 – 2 GHz	-	0.9	1.1	dB
Isolation ¹	DC – 1 GHz	25	30	-	dB
	1 – 2 GHz	22	26	-	dB
Input Return Loss ²	DC – 1 GHz	20	28	-	dB
	1 – 2 GHz	16	22	-	dB
Output Return Loss ²	DC – 1 GHz	22	28	-	dB
	1 – 2 GHz	16	22	-	dB
P1dB power compression point ³	0/-5 V control; 50 MHz	-	21	-	dBm
	0/-5 V control; 2 GHz	-	26	-	dBm
	0/-8 V control; 50 MHz	-	22	-	dBm
	0/-8 V control; 2 GHz	-	30	-	dBm
Switching Speed	50% control to 10%90% RF	-	2.2	-	ns

Notes

1. Insertion loss and Isolation measured between RF Input and any output.
2. Return Loss measured in low loss switch state.
3. Input power at which insertion loss compresses by 1dB.

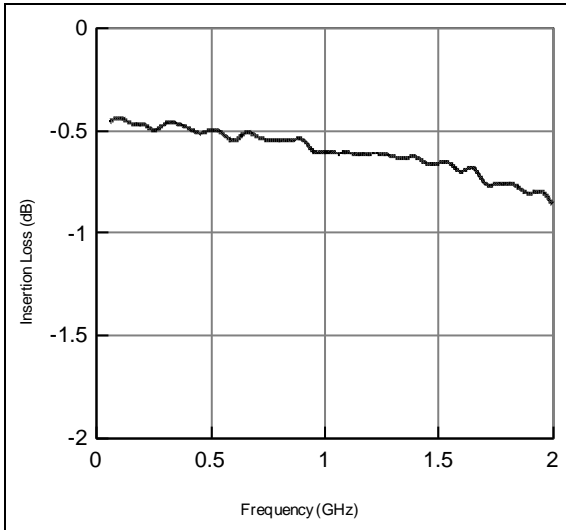
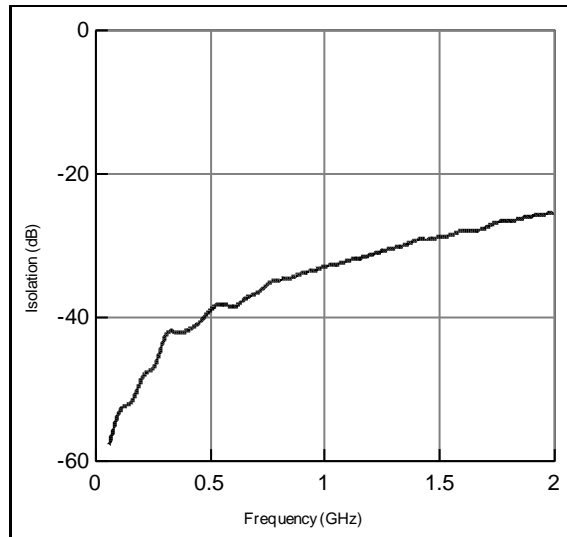
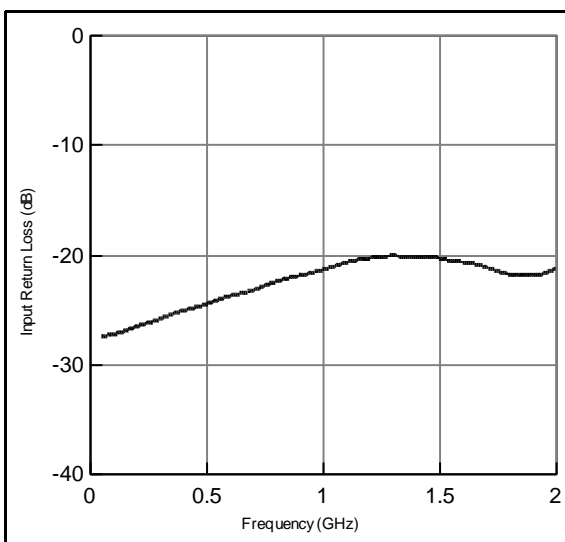
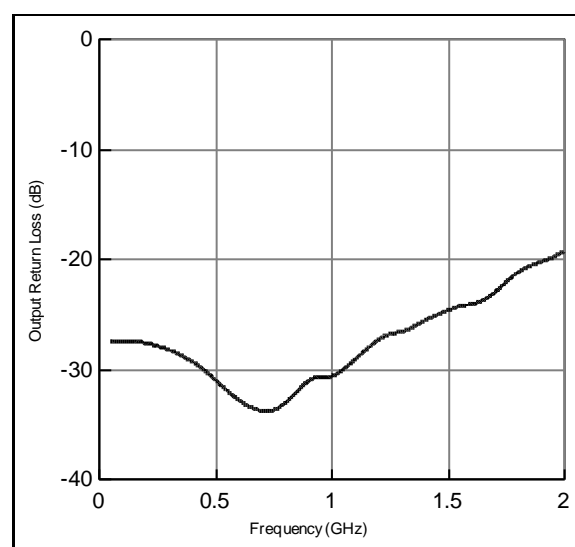
Measured Data

Insertion Loss

Isolation

Input Return Loss

Output Return Loss

Package Pin Out

Pin	Function	Pin	Function	Pin	Function	Pin	Function
1	RF4	5	RF1	9	A2	13	A3
2	Ground	6	A1	10	RF2	14	B3
3	RF IN	7	B1	11	Ground	15	B4
4	Ground	8	B2	12	RF3	16	A4

Switching Truth Table

Control Pin Voltage (V)								Path From RF IN to			
A1	B1	A2	B2	A3	B3	A4	B4	RF1	RF2	RF3	RF4
-5	0	0	-5	0	-5	0	-5	Low Loss	Isolated	Isolated	Isolated
0	-5	-5	0	0	-5	0	-5	Isolated	Low Loss	Isolated	Isolated
0	-5	0	-5	-5	0	0	-5	Isolated	Isolated	Low Loss	Isolated
0	-5	0	-5	0	-5	-5	0	Isolated	Isolated	Isolated	Low Loss

Package Drawings

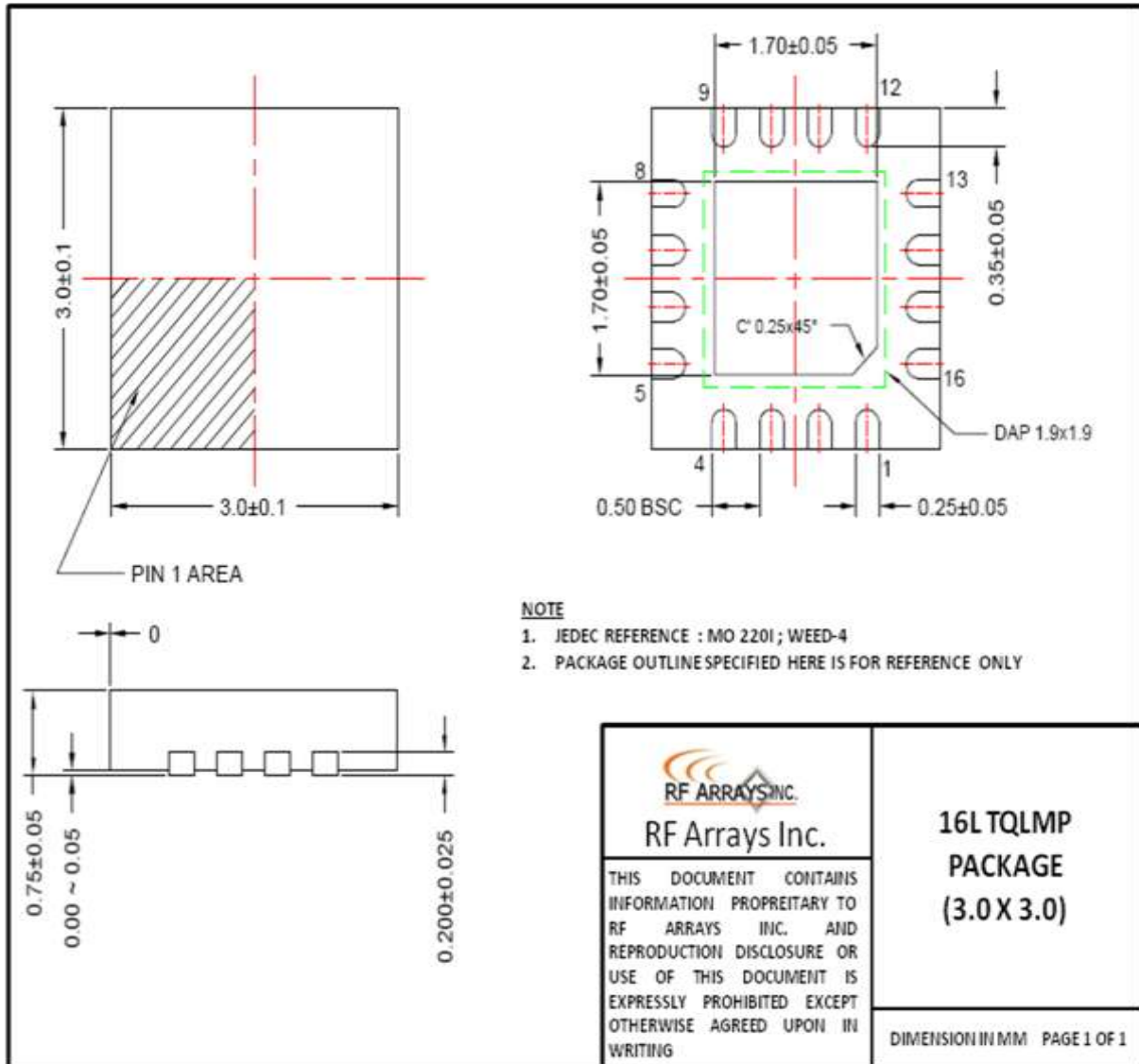

<http://www.rfarrays.com>

Customer Service Locations

USA

RF Arrays Inc.
PO Box 14948.
Fremont California 94539, USA

Email: info@rfarrays.com,
sales@rfarrays.com

INDIA

RF Arrays Systems Pvt. Ltd.
106, Infotech Towers
South Ambazari Road
Nagpur Maharashtra

Ph: 91-712-2242459
Fax: 91-712-2249429
Email: info@rfarrays.com,
sales@rfarrays.com

Product Preview

The document contains information from the product concept specification. RF Arrays Inc. reserves the right to change information at any time without notification.

Preliminary Information

The document contains information from the design target specification. RF Arrays Inc. reserves the right to change information at any time without notification.

Production testing may not include testing of all parameters.

Information furnished is believed to be accurate and reliable and is provided on an “as is” basis. RF Arrays Inc. assumes no responsibility or liability for the direct or indirect consequences of use of such information nor for any infringement of patents or other rights of third parties, which may result from its use. No license or indemnity is granted by implication or otherwise under any patent or other intellectual property rights of RF Arrays Inc. or third parties. Specifications mentioned in this publication are subject to change without notice. This publication supersedes and replaces all information previously supplied. RF Arrays Inc. products are NOT authorized for use in implantation or life support applications or systems without express written approval from RF Arrays Inc.

Copyright 2007 RF Arrays, Inc.
All Rights Reserved